

eX205 Web Tech-Note

5" Web based HMI, Capacitive Touchscreen, 1 Ethernet Port

- 5" TFT color display
- 800x480 pixel resolution, 16.7M colors
- Capacitive Multitouch
- 64-bit CPU, 1.6 GHz
- 1 Ethernet ports
- Web Browser
- CORVINA Remote Connectivity - Option



Highlights

The HMIs of eX200 Web Series combine top web browsing performance with technical specification, features and performance that make them the ideal choice for edge devices where the requirements of applications in Industry 4.0 are the data control and the visualization.

The pSLC configuration of the flash memory is a great choice for long life applications that will write substantial amount of data over the life of the product. The power of the 64 bit processing platform running Linux and state-of-the-art cybersecurity design make these products great players in modern applications.

HTML5 web application interfaces are used to display and interact with real time data. As a Web HMI, the eX200 series HMIs can easily display HTML5 data from multiple devices.

eX200 Web Series products offer great integration options in enterprise networks and cloud communication. When used in combination with services by CORVINA, remote connectivity and smart data sharing are available for optimal performance in smart factory applications.

eX205 Web Technical Data

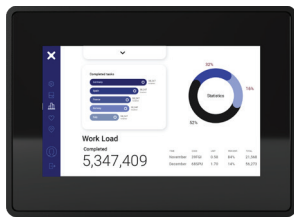

System Resources	
Display - Colors	5" - 16.7 M
Resolution	800x480
Brightness	400 Cd/m ² typ.
Dimming	Yes
Touchscreen	Projected Capacitive - Multitouch
CPU	64-bit RISC quad core - 1.6GHz
Operating System	Linux
Flash	4 GB (pSLC mode - High reliability)
RAM	2 GB
Real Time Clock	Yes
RTC Back-up	Supercapacitor
Interface	
Ethernet port	1 (10/100 Mbit)
USB port	1 (Host v. 2.0, max. 500 mA)
Buzzer	Yes
Indicator Light	1 (RGB LED)
Ratings	
Power supply	24 Vdc (9 to 32 Vdc)
Current Consumption	0.35 A max. at 24 Vdc
Input Protection	Electronic
Environment Conditions	
Operating Temperature	-20°C to +55°C (vertical installation)
Storage Temperature	-30°C to +70°C
Operating / Storage Humidity	5-85% RH, non condensing
Protection Class	IP66 (front), IP20 (rear)
Dimensions and Weights	
Faceplate LxH	147x107 mm (5.79x4.21")
Cutout AxB	136x96 (5.35"x3.78")
Depth D+T	29+8 mm (1.14+0.31")
Weight	0.5 Kg
Approvals	
CE	Electromagnetic Compatibility Directive 2014/30/EU (EMC)
UL*	cULus: UL61010-1 / UL61010-2-201
RCM	Yes

* Roadmap 2024

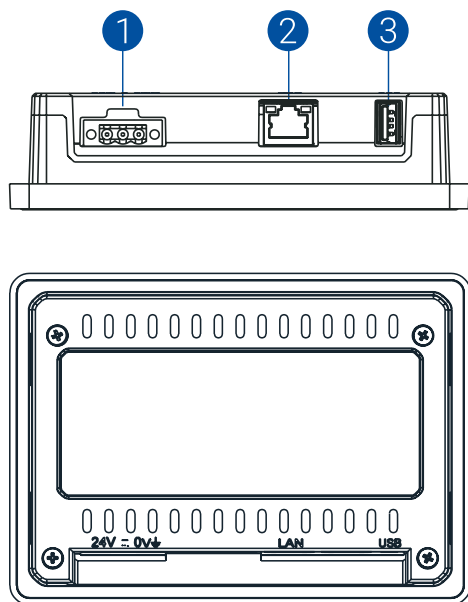

- 1 Power Supply
- 2 Ethernet Port
- 3 USB port (vers. 2.0-1.1)

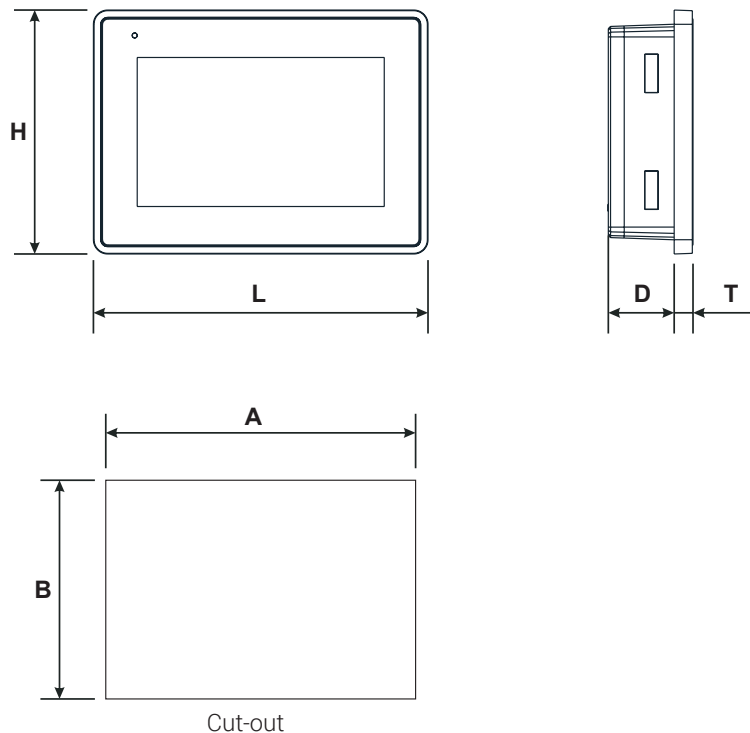

Ordering Information

Model	Ordering Code	Part Number	Description
eX205 Web	101006200U-0001-01	+EX205U50W	5" Web based HMI, Capacitive Touchscreen, 1 Ethernet Port.